

- Primarily designed for convenient in multiple connections
- Covered an extensive range of voltages and current ratings
- Agency approvals
 - UL: / C-UL #E200679
 - TUV: #R9924372
- Custom-made line filters are available upon request.

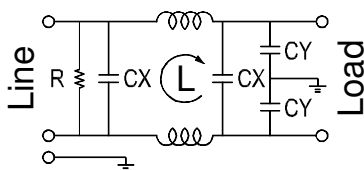

Circuit A

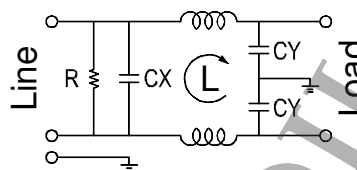

Circuit B

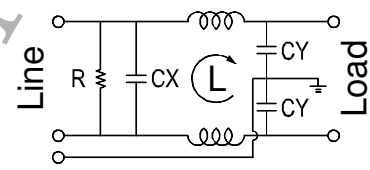

Circuit C

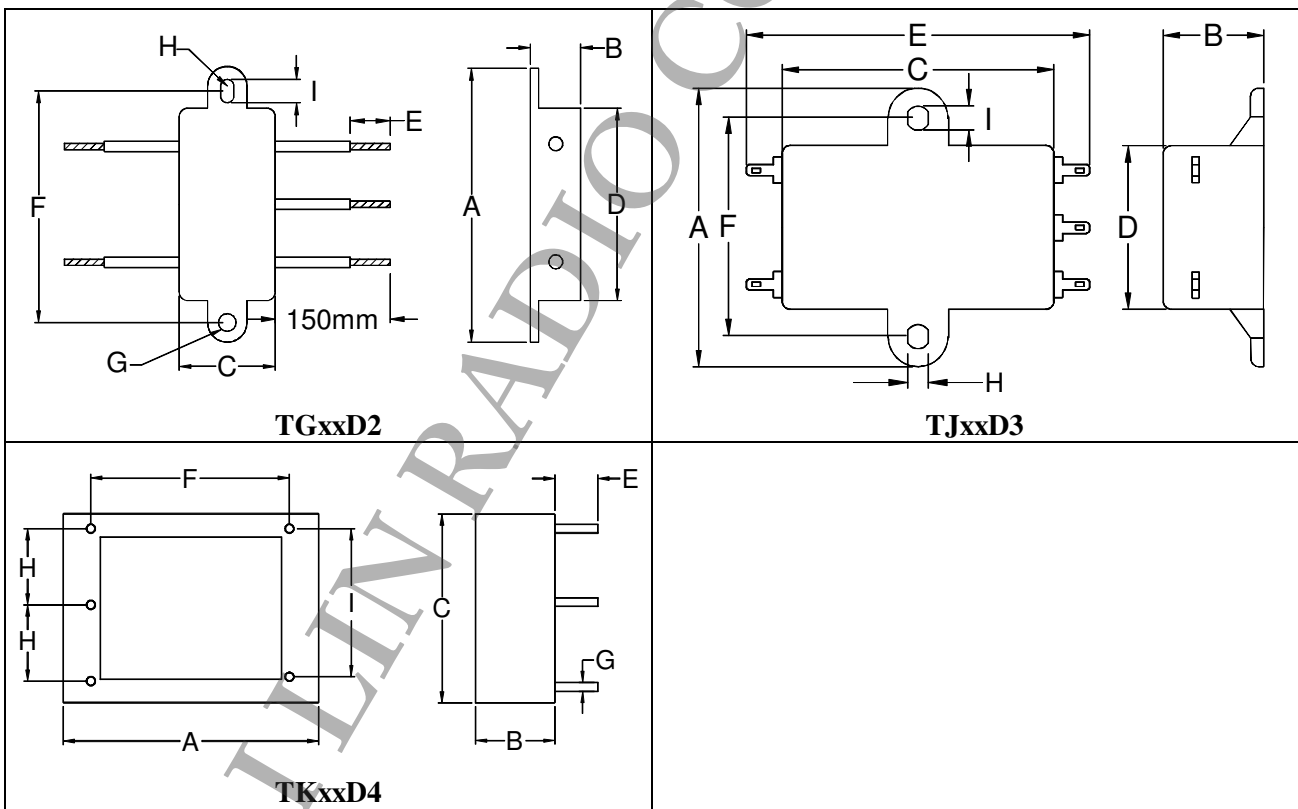

Product Series	Dimension (mm)									Circuit	Weight (g)
	A	B	C	D	E	F	G	H	I		
TGxxD2	65.0	18.0	24.0	46.0	10.0	53.0	Ø4.0	R2.0	6.0	B	46
TJxxD3	52.0	28.0	52.0	34.0	70.0	40.0	--	3.7	4.4	C	35
TKxxD4	42.0	22.0	32.0	--	7.0	27.0	Ø1.2	10.0	20.0	C	37
Tolerance	max.	max.	max.	max.	± 2.0	± 1.0	ref.	± 1.0	± 1.0	--	approx.

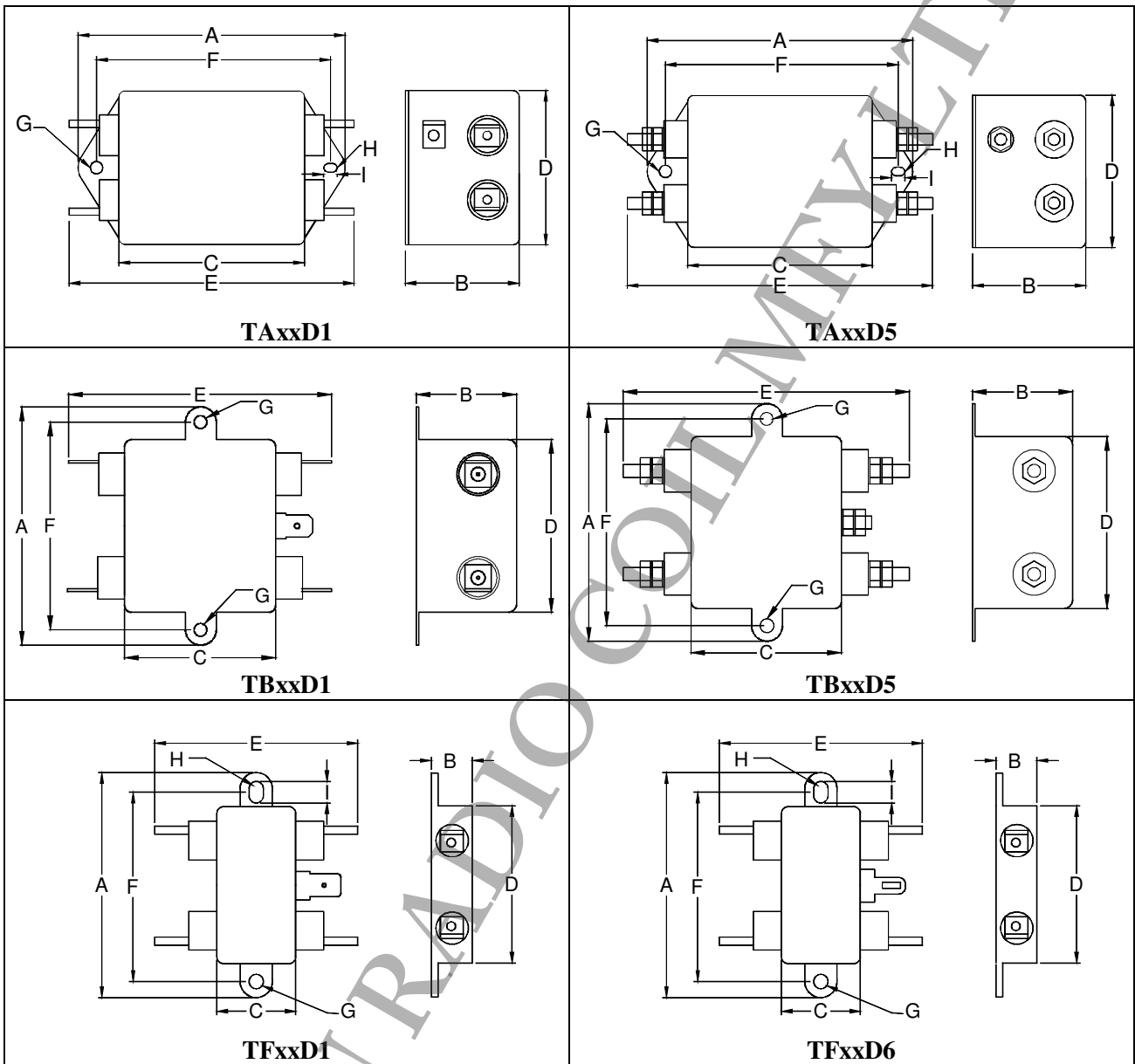

Product Series	Dimension (mm)									Circuit	Weight (g)
	A	B	C	D	E	F	G	H	I		
TAxxD1	91.0	39.0	63.0	53.0	92.5	75.0	Ø4.8	R2.0	6.0	A	195
TAxxD5	91.0	39.0	63.0	53.0	101.5	75.0	Ø4.8	R2.0	6.0	A	185
TBxxD1	73.0	31.0	45.0	52.0	75.0	60.0	Ø4.8	--	--	A	120
TBxxD5	73.0	31.0	45.0	52.0	83.5	60.0	Ø4.8	--	--	A	120
TFxxD1	65.0	19.0	24.0	46.0	54.0	53.0	Ø4.0	R2.0	6.0	B	45
TFxxD6	65.0	19.0	24.0	46.0	54.0	53.0	Ø4.0	R2.0	6.0	B	45
Tolerance	max.	max.	max.	max.	± 2.0	± 1.0	ref.	± 1.0	± 1.0	--	approx.

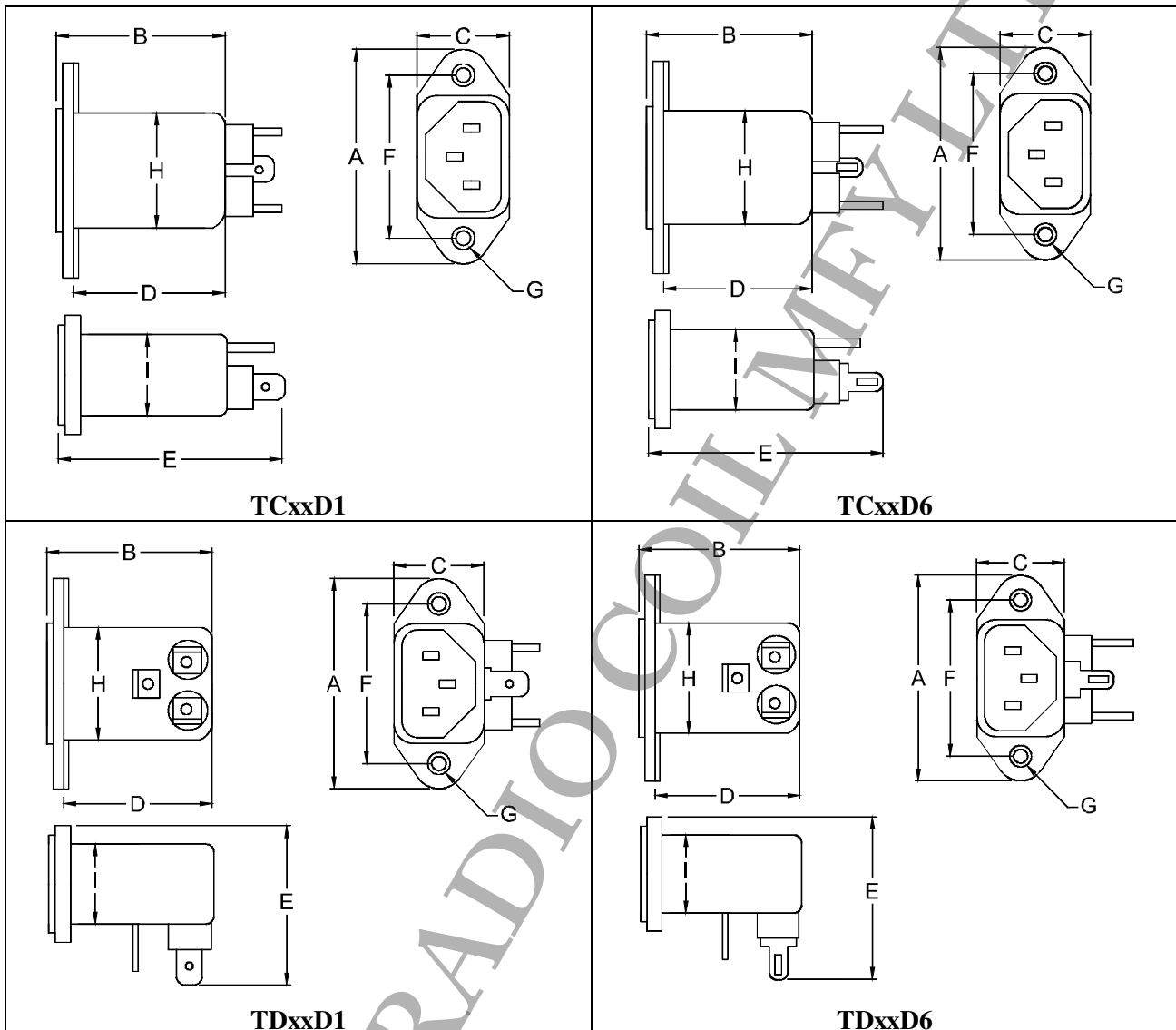

Product Series	Dimension (mm)										Circuit	Weight (g)
	A	B	C	D	E	F	G	H	I			
TCxxD1	53.0	45.0	25.0	36.3	58.5	40.0	Ø3.5	28.2	19.4	B	41	
TCxxD6	53.0	45.0	25.0	36.3	58.5	40.0	Ø3.5	28.2	19.4	B	41	
TDxxD1	53.0	45.0	25.0	36.3	36.0	40.0	Ø3.5	28.2	19.4	B	43	
TDxxD6	53.0	45.0	25.0	36.3	36.0	40.0	Ø3.5	28.2	19.4	B	43	
Tolerance	max.	max.	max.	± 1.0	± 2.0	± 1.0	ref.	± 1.0	± 1.0	--	approx.	

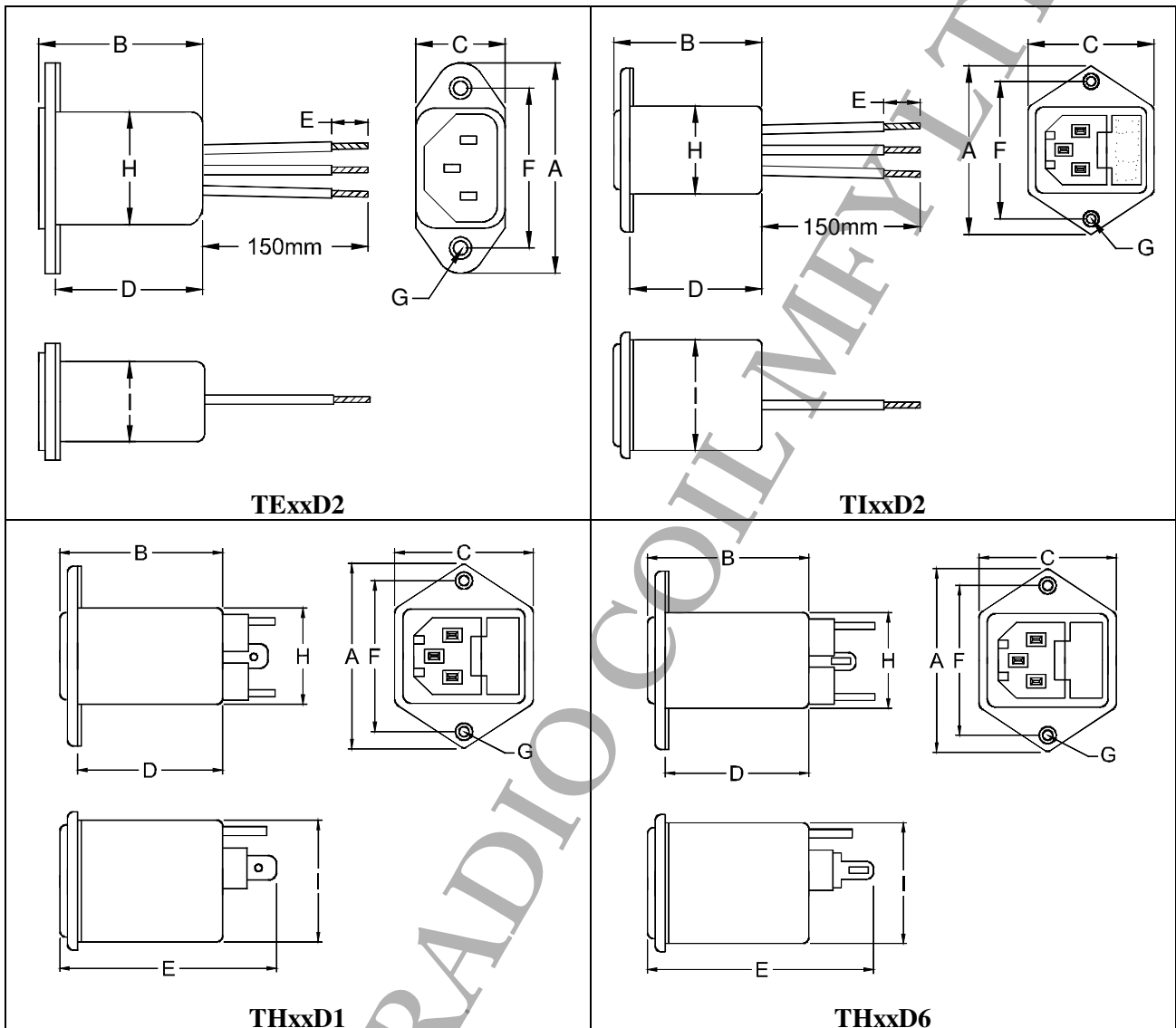

Product Series	Dimension (mm)										Circuit	Weight (g)
	A	B	C	D	E	F	G	H	I			
TExxD2	53.0	45.0	25.0	36.3	10.0	40.0	Ø3.5	28.2	19.4	B	50	
TIxxD2	47.0	52.0	36.0	43.3	10.0	36.0	Ø3.5	28.2	32.4	B	57	
THxxD1	47.0	52.0	36.0	43.3	65.0	36.0	Ø3.5	28.2	32.4	B	63	
THxxD6	45.0	52.0	36.0	43.3	65.0	36.0	Ø3.5	28.2	32.4	B	63	
Tolerance	max.	max.	max.	± 1.0	± 2.0	± 1.0	ref.	± 1.0	± 1.0	--	approx.	

AC Rated Voltage (V)	Part Number	AC Rated Current (A)	Frequency Range (Attenuation / 25 dB)		Part Number	AC Rated Current (A)	Frequency Range (Attenuation / 25 dB)	
			Normal Mode (MHz)	Common Mode (MHz)			Normal Mode (MHz)	Common Mode (MHz)
250	TA05D1	5	0.20 – 50	0.18 – 50	TF01D1	1	0.20 – 50	0.45 – 50
	TA10D1	10	0.28 – 50	0.25 – 50	TF03D1	3	0.20 – 50	0.20 – 50
	TA15D1	15	0.25 – 50	0.23 – 50	TF06D1	6	0.20 – 50	0.40 – 50
	TA20D1	20	0.18 – 50	0.40 – 50	TF10D1	10	0.25 – 50	0.45 – 50
	TA05D5	5	0.20 – 50	0.18 – 50	TF01D6	1	0.20 – 50	0.45 – 50
	TA10D5	10	0.28 – 50	0.25 – 50	TF03D6	3	0.20 – 50	0.20 – 50
	TA15D5	15	0.25 – 50	0.23 – 50	TF06D6	6	0.20 – 50	0.40 – 50
	TA20D5	20	0.18 – 50	0.40 – 50	TF10D6	10	0.25 – 50	0.45 – 50
	TB05D1	5	0.20 – 45	0.20 – 45	TG01D2	1	0.25 – 50	0.45 – 50
	TB10D1	10	0.25 – 50	0.25 – 50	TG03D2	3	0.20 – 50	0.25 – 50
	TB15D1	15	0.30 – 50	0.30 – 50	TG06D2	6	0.25 – 50	0.40 – 50
	TB20D1	20	0.20 – 50	0.40 – 50	TG10D2	10	0.25 – 50	0.40 – 50
	TB05D5	5	0.20 – 45	0.20 – 45	TH01D1	1	0.20 – 50	0.25 – 50
	TB10D5	10	0.25 – 50	0.25 – 50	TH03D1	3	0.18 – 50	0.20 – 50
	TB15D5	15	0.30 – 50	0.30 – 50	TH06D1	6	0.20 – 50	0.40 – 50
	TB20D5	20	0.20 – 50	0.40 – 50	TH10D1	10	0.25 – 50	0.45 – 50
	TC01D1	1	0.25 – 50	0.45 – 50	TH01D6	1	0.20 – 50	0.25 – 50
	TC03D1	3	0.20 – 50	0.25 – 50	TH03D6	3	0.18 – 50	0.20 – 50
	TC06D1	6	0.20 – 50	0.40 – 50	TH06D6	6	0.20 – 50	0.40 – 50
	TC10D1	10	0.25 – 50	0.45 – 50	TH10D6	10	0.25 – 50	0.45 – 50
	TC01D6	1	0.25 – 50	0.45 – 50	TI01D2	1	0.20 – 50	0.45 – 50
	TC03D6	3	0.20 – 50	0.25 – 50	TI03D2	3	0.18 – 50	0.20 – 50
	TC06D6	6	0.20 – 50	0.40 – 50	TI06D2	6	0.20 – 50	0.40 – 50
	TC10D6	10	0.25 – 50	0.45 – 50	TI10D2	10	0.30 – 50	0.90 – 50
	TD01D1	1	0.20 – 50	0.45 – 50	TJ01D3	1	0.20 – 50	0.45 – 50
	TD03D1	3	0.20 – 50	0.25 – 50	TJ03D3	3	0.18 – 50	0.20 – 50
	TD06D1	6	0.20 – 50	0.40 – 50	TJ06D3	6	0.20 – 50	0.40 – 50
	TD10D1	10	0.25 – 50	0.45 – 50	TJ10D3	10	0.25 – 50	0.45 – 50
	TD01D6	1	0.20 – 50	0.45 – 50	TK01D4	1	0.20 – 50	0.45 – 50
	TD03D6	3	0.20 – 50	0.25 – 50	TK03D4	3	0.18 – 50	0.20 – 50
	TD06D6	6	0.20 – 50	0.40 – 50	TK06D4	6	0.20 – 50	0.40 – 50
	TD10D6	10	0.25 – 50	0.45 – 50	TK10D4	10	0.35 – 50	0.90 – 50
	TE01D2	1	0.20 – 50	0.45 – 50				
	TE03D2	3	0.20 – 50	0.25 – 50				
	TE06D2	6	0.20 – 50	0.40 – 50				
	TE10D2	10	0.30 – 50	0.90 – 50				