

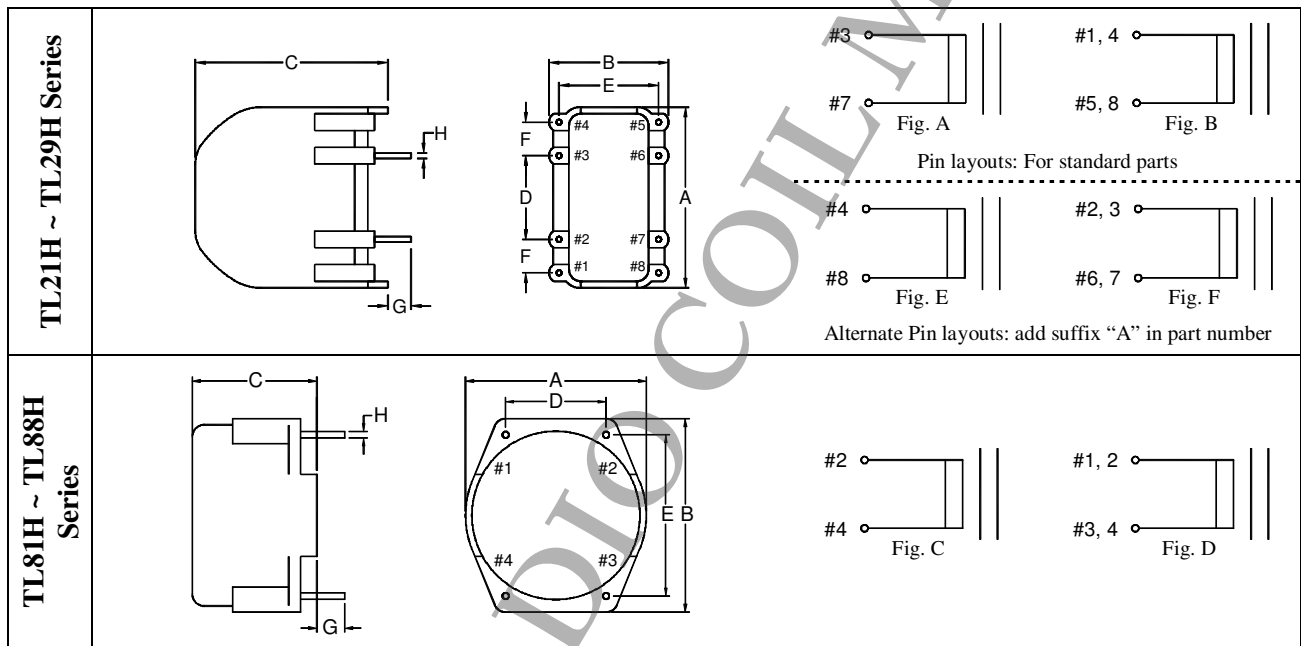

- Horizontal & Vertical Series
- Inductance range : 63 ~ 4000 μ H
- Current range : 1.0 ~ 10A
- Custom-made chokes are available upon request.



Product Series	Dimension (mm)								Weight (g)
	A	B	C	D	E	F	G	H	
TL21H	18.0	12.4	20.0	5.0	10.0	5.0	3.5	Ø0.8	5
TL22H	23.0	15.2	25.0	10.0	12.5	5.0	3.5	Ø0.8	13
TL23H	27.0	18.0	29.0	12.5	15.0	5.0	3.5	Ø0.8	20
TL24H	32.0	18.0	33.5	12.5	15.0	7.5	3.5	Ø0.8	27
TL25H	32.0	20.6	36.0	12.5	17.5	7.5	3.5	Ø0.8	32
TL26H	37.0	25.5	40.0	15.0	22.5	7.5	3.5	Ø0.8	37
TL27H	43.0	28.2	45.0	25.0	25.0	7.5	3.5	Ø0.8	62
TL28H	49.0	33.7	52.0	25.0	30.0	10.0	3.5	Ø1.0	110
TL29H	63.6	44.0	59.0	25.0	40.0	10.0	3.5	Ø1.0	142
TL81H	17.0	18.0	12.5	10.0	15.0	--	3.5	Ø0.8	5
TL82H	22.5	24.0	15.5	12.5	20.0	--	3.5	Ø0.8	10
TL83H	27.0	28.3	17.5	15.0	25.0	--	3.5	Ø0.8	17
TL84H	32.0	33.2	19.5	20.0	30.0	--	3.5	Ø0.8	26
TL85H	37.0	41.5	20.5	20.0	35.0	--	3.5	Ø0.8	40
TL86H	42.0	42.0	28.0	25.0	35.0	--	3.5	Ø0.8	58
TL87H	47.0	47.0	30.0	30.0	40.0	--	3.5	Ø1.0	87
TL88H	52.0	52.0	40.0	35.0	45.0	--	3.5	Ø1.0	133
Tolerance	± 1.0	± 1.0	± 1.0	± 0.5	± 0.5	± 0.5	± 0.5	± 0.1	approx.

Part Number	Current (A)	Inductance (μH)	DCR (Ω)	Fig.	Part Number	Current (A)	Inductance (μH)	DCR (Ω)	Fig.
*TL22H100	1	125	0.150	A	TL82H100	1	125	0.150	C
*TL23H101	1	400	0.210	A	TL83H101	1	400	0.210	C
*TL24H102	1	2500	0.700	A	TL84H102	1	2500	0.700	C
*TL22H103	1.6	50	0.070	A	TL82H103	1.6	50	0.070	C
*TL23H104	1.6	400	0.180	A	TL83H104	1.6	400	0.180	C
*TL24H105	1.6	1000	0.290	A	TL84H105	1.6	1000	0.290	C
*TL23H106	2.5	160	0.073	A	TL83H106	2.5	160	0.073	C
*TL24H107	2.5	400	0.140	A	TL84H107	2.5	400	0.140	C
*TL26H108	2.5	1000	0.225	A	TL85H108	2.5	1000	0.225	C
*TL27H109	2.5	1600	0.307	A	TL86H109	2.5	1600	0.307	C
*TL28H110	2.5	2500	0.350	A	TL87H110	2.5	2500	0.350	C
*TL25H111	3.15	250	0.083	A	TL84H111	3.15	250	0.083	C
*TL26H112	3.15	630	0.148	A	TL85H112	3.15	630	0.148	C
*TL27H113	3.15	1000	0.170	A	TL86H113	3.15	1000	0.170	C
*TL29H114	3.15	4000	0.365	A	TL88H114	3.15	4000	0.365	C
*TL25H115	4	160	0.059	A	TL84H115	4	160	0.059	C
*TL26H116	4	400	0.103	A	TL85H116	4	400	0.103	C
*TL27H117	4	630	0.110	A	TL86H117	4	630	0.110	C
*TL28H118	4	1000	0.142	A	TL87H118	4	1000	0.142	C
*TL29H119	4	2500	0.235	A	TL88H119	4	2500	0.235	C
*TL25H120	5	100	0.035	A	TL84H120	5	100	0.035	C
*TL26H121	5	250	0.058	A	TL85H121	5	250	0.058	C
*TL27H122	5	400	0.080	A	TL86H122	5	400	0.080	C
*TL29H123	5	1600	0.150	A	TL88H123	5	1600	0.150	C
*TL25H124	6.3	63	0.025	A	TL84H124	6.3	63	0.025	C
*TL26H125	6.3	160	0.035	A	TL85H125	6.3	160	0.035	C
*TL29H126	6.3	1000	0.095	B	TL88H126	6.3	1000	0.095	D
*TL27H127	8	125	0.025	B	TL86H127	8	125	0.025	D
*TL28H128	8	250	0.042	B	TL87H128	8	250	0.042	D
*TL29H129	8	630	0.060	B	TL88H129	8	630	0.060	D
*TL26H130	10	63	0.018	B	TL85H130	10	63	0.018	D
*TL27H131	10	100	0.018	B	TL86H131	10	100	0.018	D
*TL28H132	10	160	0.027	B	TL87H132	10	160	0.027	D
*TL29H133	10	400	0.035	B	TL88H133	10	400	0.035	D

* Items with suffix "A" are available (e.g. TL22H100A). The corresponding pin layouts are as followed:

- 1) Fig. E replaces Fig. A
- 2) Fig. F replaces Fig. B