

## Flyback Transformer

- Core Type: EF20
- Maximum Output Power: 24W
- Primary / Secondary Insulation – 4000Vrms
- Primary / Secondary Creepage – 6mm min.
- Triple insulated wire is used to provide reinforced insulation between windings.
- Insulation Material Class F (155°C)
- Construction conforms to EN 61558, EN 60950, & EN 60065.
- Agency Approvals – UL 60950-1, CAN/CSA C22.2 No. 60950-1-07.
- Custom-made transformers are available upon request.

### Bobbin Type 1 & Available Schematics:

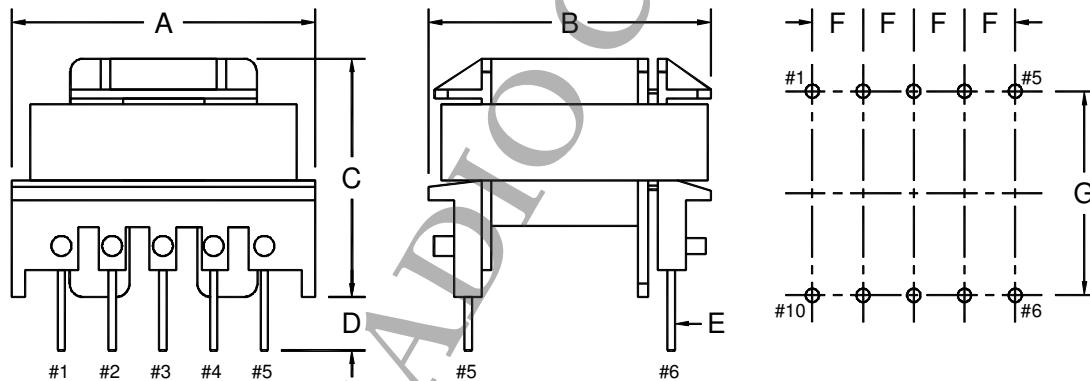

	A	B	C	D	E	F	G	Weight (g)
<b>Dimension (mm)</b>	23.7	22.2	19.5	3.5	SQ0.5	3.81	15.24	14.0
<b>Tolerance (mm)</b>	max.	max.	max.	±1.0	±0.1	±0.2	±0.5	approx.

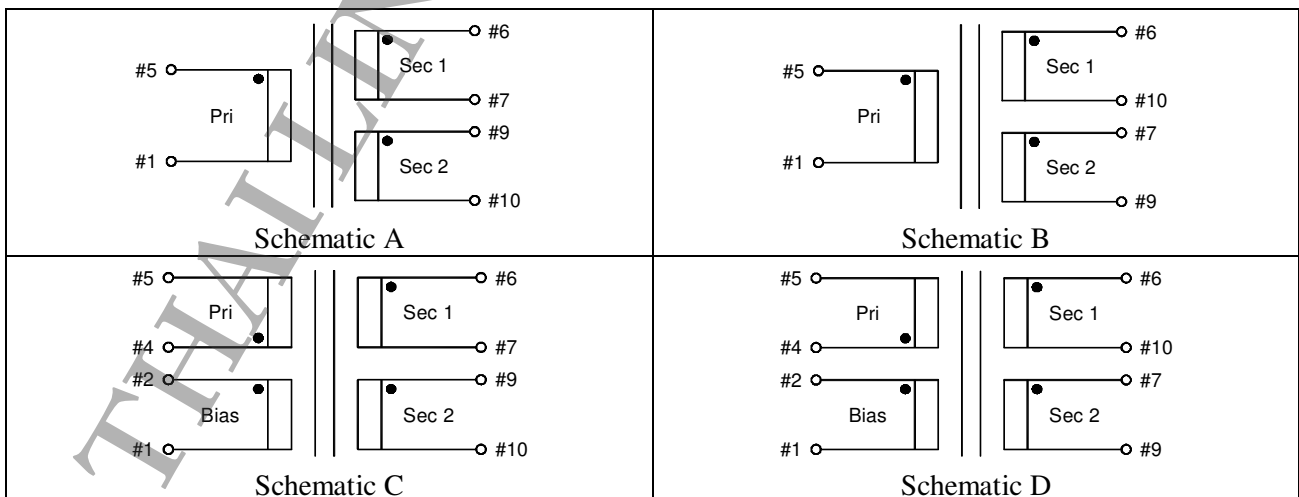

## Bobbin Type 2 & Available Schematics

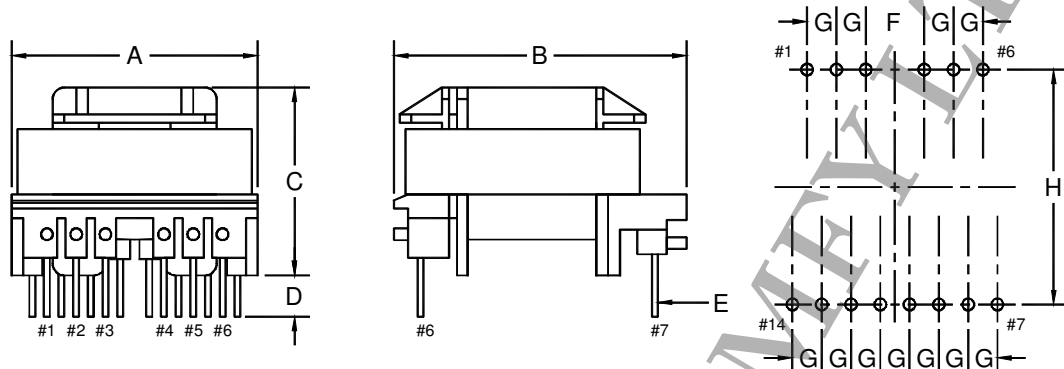

	A	B	C	D	E	F	G	H	Weight (g)
<b>Dimension (mm)</b>	22.0	26.0	17.5	3.5	SQ0.5	5.0	2.5	20.0	14.5
<b>Tolerance (mm)</b>	max.	max.	max.	±1.0	±0.1	±0.2	±0.2	±0.5	approx.

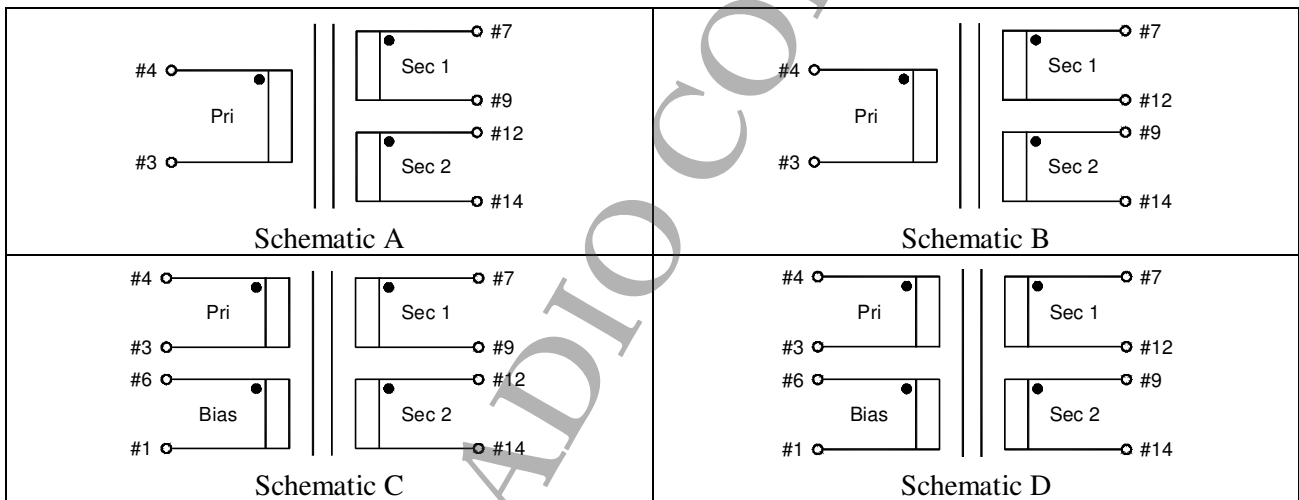

## Bobbin Type 3:

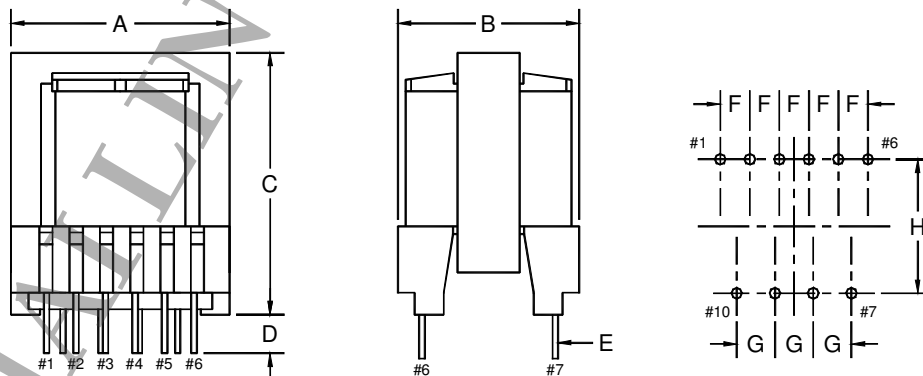

	A	B	C	D	E	F	G	H	Weight (g)
<b>Dimension (mm)</b>	21.5	17.5	25.0	3.5	SQ0.5	2.7	3.5	12.2	15.0
<b>Tolerance (mm)</b>	max.	max.	max.	±1.0	±0.1	±0.2	±0.2	±0.5	approx.

### Available Schematics for Bobbin Type 3:

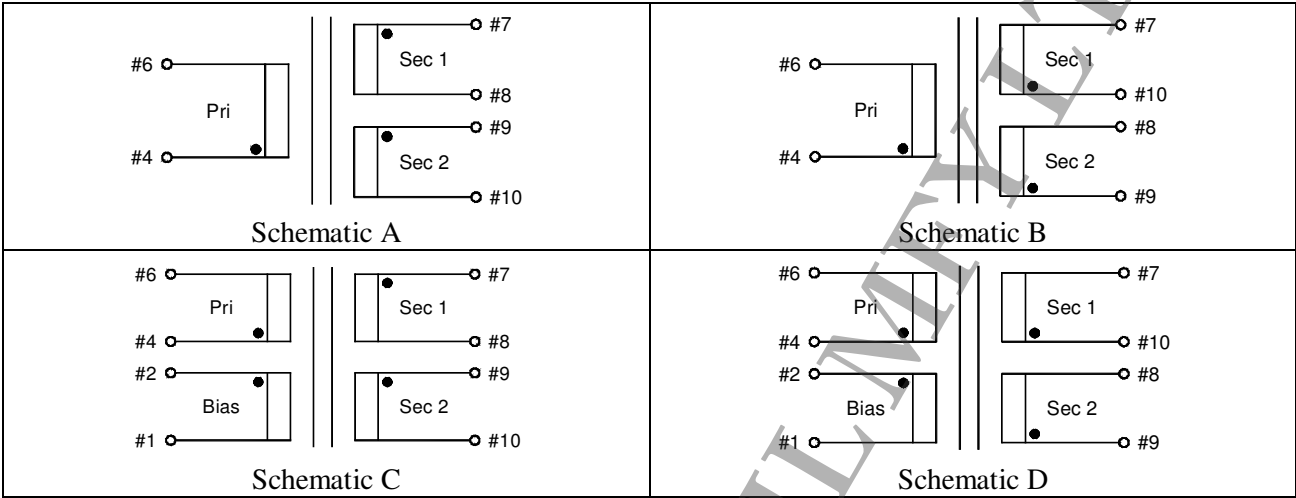

### Available Items:

Product Series	Power	Secondary Voltage	Bobbin Type & Schematic
TL483A (working frequency=132kHz)	12 (=12W) 14 (=14W) 15 (=15W) 18 (=18W) 20 (=20W) 22 (=22W) 24 (=24W)	A (=3V) B (=5V) C (=6V) D (=10V) E (=12V) F (=15V) G (=20V) H (=24V)	1A; 1B; 1C; 1D 2A; 2B; 2C; 2D 3A; 3B; 3C; 3D

### Part Number Designation:

TL483v-wwxyz

Where v = working frequency (A = 132kHz)  
 ww = maximum output power  
 x = secondary voltage  
 y = available bobbin type  
 z = available schematic

Example: TL483A-20CC3D = 132kHz / 20W / 6V + 6V / Bobbin Type 3 / 2 outputs + bias

### Example of application with Integrated Circuits:

Product Series	Power (W)	IC Manufacturer	IC P/N	Primary Voltage (V)	Working Frequency (kHz)
TL483A	12	Power Integrations	TOP243P	85-265	132
TL483A	14	Power Integrations	TNY267/277	85-265	132
TL483A	15	Power Integrations	TOP243P	85-265	132
TL483A	18	Power Integrations	TNY268/278	185-265	132
TL483A	20	Power Integrations	TOP243P	185-265	132
TL483A	22	Power Integrations	TOP242/243	185-265	132
TL483A	24	Power Integrations	TOP243P	185-265	132